



## FORM-20-SM-WM-L10-HVG

Form 20M Exit, Surface Wall Mount, L10 Nanophosphate, Zoneworks XT Hive, All Pictograms, Single Sided, Brushed Aluminium Frame



PRODUCT INFORMATION	
Product Code	FORM-20-SM-WM-L10-HVG
MIC	UKA01810170002
Description	Form 20M Exit, Surface Wall Mount, L10 Nanophosphate, Zoneworks XT Hive, All Pictograms, Single Sided, Brushed Aluminium Frame
Construction	Cast Aluminium Box with PC/Aluminium Extrusion Blade
Diffuser	Polycarbonate
Mounting	Wall Mount, Single Sided
Electrical Connection	Push Terminal
Viewing Distance	20m
Operating Mode	Maintained
Testing System	Zoneworks XT HIVE (RF)
Battery	Lithium Nanophosphate, 3.3V 2500mAh
Charging Method	Intelligent Current Limited Constant Voltage
Lamp(s)*	18 x LED, 170,000 hours
Supply Voltage	220-240V~ 50Hz
Power Factor	0.28 (Standby, Maintained), 0.42 (Max)
Supply Current	19.91 (Standby, Maintained), 35.60 (Max) - (mA)
Inrush Current (Max)	10A<144µs
Earth Leakage	0.35mA
Power Consumption	1.5W (Standby), 3.6W (Max)
Operating Temperature	0 °C - 40°C
IP Rating	IP42
Impact Rating	IK03
Rated Emergency Duration	180 Minutes
Compliance Marking	
Protection	<ul style="list-style-type: none"><li>• Battery overvoltage &amp; overcurrent protection</li><li>• Battery deep discharge protection</li><li>• Supply voltage polarity reversal protection</li><li>• Battery short-circuit protection (charging will resume upon removal of fault)</li></ul>
Luminaire Classification	X   1   AFG   180
Conformity	BS EN 55015, BS EN 61547, BS EN 61000-3-2, BS EN 61000-3-3, ETSI EN 301 489-1, ETSI EN 301 489-17, BS EN 1838, BS EN ISO 7010, BS EN 62471, BS EN 60598-2-22



## FORM-20-SM-WM-L10-HVG

Form 20M Exit, Surface Wall Mount, L10 Nanophosphate,  
Zoneworks XT Hive, All Pictograms, Single Sided,  
Brushed Aluminium Frame

DIMENSIONS	
Blade Assembly (LxWxH mm)	220 x 18 x 110
Body/Box (LxWxH mm)	220 x 58 x 45
Minimum Depth (mm)	0
Weight (kg)	0.80

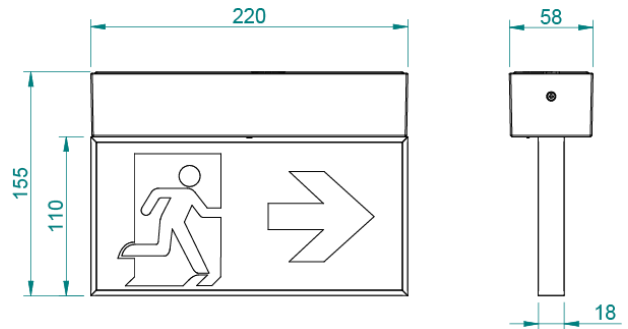

REPLACEMENT PARTS	
PART NUMBER	DESCRIPTION
1533050	Battery
8011952	LED Assembly
UKM01870320002 LLEDDRV2CH-VR-2C170-6C30-15-CKIT-HVG	Emergency Driver

The product details described in this document are current as at the version date of the document. We reserve the right to change product design, specifications or materials (Specifications) as part of our continuous improvement program. Please confirm the applicable Specifications at the time of placing your order