



FORM-20-REC-CM-CS-REM-LP-HVG

CLEVERTRONICS Form 20m Exit, Recessed Ceiling Mount, Cable Suspended, Remote Gear, CLP, Zoneworks XT Hive, Picto All, Double Sided, Brushed Aluminium Frame



PRODUCT INFORMATION - GENERAL

Product Code	FORM-20-REC-CM-CS-REM-LP-HVG
MIC	UKA02810210001
Description	Form 20m Exit, Recessed Ceiling Mount, Cable Suspended, Remote Gear, CLP, Zoneworks XT Hive, Picto All, Double Sided, Brushed Aluminium Frame
Construction	PC/Aluminium Extrusion Blade, with remote hardware
Diffuser	Polycarbonate
Mounting	Recessed Ceiling Mount, Double Sided
Electrical Connection	Push Terminal

PRODUCT INFORMATION - SPECIFICATIONS

Viewing Distance	20m
Operating Mode	Maintained
Testing System	Zoneworks XTHIVE (RF)
Battery	Lithium Iron Phosphate, 3.2V 1100mAh
Charging Method	Intelligent Current Limited Constant Voltage
Lamp(s)*	18 x LED, 170,000 hours
Supply Voltage	220-240V~ 50Hz
Power Factor	0.28 (Standby, Maintained), 0.42 (Max)
Supply Current	19.91 (Standby, Maintained), 35.60 (Max) - (mA)
Inrush Current (Max)	10A<144μs
Earth Leakage	0.35
Power Consumption	1.5W (Standby), 3.6W (Max)
Operating Temperature	0 °C - 40°C
IP Rating	IP20
Impact Rating	IK03
Rated Emergency Duration	180 Minutes
Escape Route Illumination	N/A
Escape Route Illumination Emergency Lumens	N/A



FORM-20-REC-CM-CS-REM-LP-HVG

CLEVERTRONICS Form 20m Exit, Recessed Ceiling Mount, Cable Suspended, Remote Gear, CLP, Zoneworks XT Hive, Picto ALL, Double Sided, Brushed Aluminium Frame

PRODUCT INFORMATION - COMPLIANCE

Protection	<ul style="list-style-type: none"> • Battery Overvoltage & Overcurrent Protection • Battery Deep Discharge Protection • Supply Voltage Polarity Reversal Protection • Battery Short-circuit Protection (Charging Will Resume Upon Removal of Fault) • Kit Box (Enclosure) of Lamp Control Gear Provides Protection Against Accidental Contact With Live Parts
Luminaire Classification	X 1 AFG 180
Conformity	BS EN 55015, BS EN 61547, BS EN 61000-3-2, BS EN 61000-3-3, ETSI EN 301 489-1, ETSI EN 301 489-17, BS EN 1838, BS EN ISO 7010, BS EN 62471, BS EN 60598-2-22
Compliance Marking	UK CA CE

REPLACEMENT PARTS

COMPONENT	PART NUMBER & DESCRIPTION
1550092	Battery
UKM02870260001 CLEDDRV2CH-RR-2C170-6C30-15-CKIT-HVG	Emergency Driver
8003335	Emergency Node

PRODUCT INFORMATION - DIMENSIONS

Blade Assembly (LxWxH mm)	220 x 18 x 110
Body/Box (LxWxH mm)	N/A
Rod/Cable (LxDIAØ mm)	1500 x 1.4
Cut-Out (LxW mm)	17mm hole (x2), 12mm hole (x1)
Minimum Depth (mm)	150
Weight (kg)	0.55

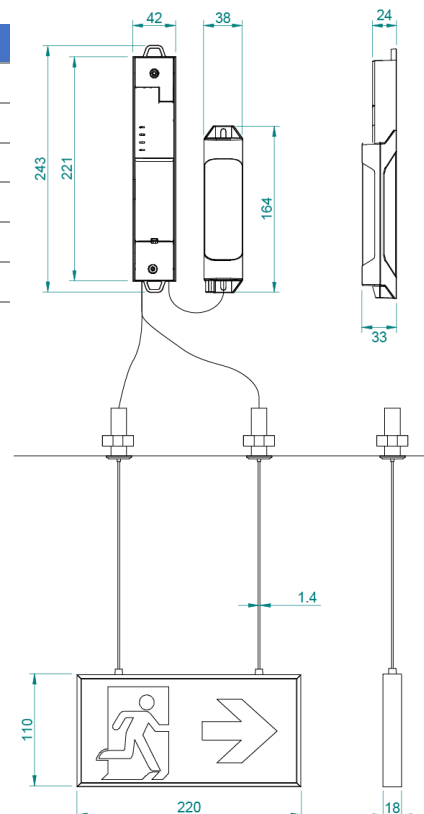

*The projected value has been calculated by extrapolation of the LM80 data using the Energy Star Calculator

The product details described in this document are current as at the version date of the document. We reserve the right to change product design, specifications, or materials (Specifications) as part of our continuous improvement program. Please confirm the applicable Specifications at the time of placing your order