

Clevertest Plus



Clevertest products must be “activated” before self-test functionality will operate. Refer to supplementary operation guide supplied with the Product or linked via QR code on packaging for details.

After Power ON, the Status LED on a Clevertest Plus enabled fitting will display a rapid Green or Red flashing for a period up to 2 minutes.

To register the fitting into Clevertest Plus app see supplementary guide.

Zoneworks, HIVE and DATA Monitored Options

Fittings with part numbers -ZW, -HVG, -DATA are fitted with Zoneworks communications modules (nodes). These fittings are monitored using either Powerline Carrier Technology that utilize the power cable to provide data communication, RF transceiver modules operating in the ISM band or a dedicated data cable to/from data routers installed on a dedicated data trunk connected to a central Server (can also be connected via Ethernet/Internet/Fibre). Zoneworks software on the server is used to monitor, coordinate testing and collate test data from each fitting. Zoneworks Fittings can be commissioned by a single push of the test switch or by scanning the supplied barcode. The LED Test Switch indicator provides a multifunction indication of the status of the fitting during testing and normal operation:

Option	State	LED Operation
ZW, HVG, DATA	Commissioned	LED on Solid (Green)
ZW, DATA	Un-commissioned	Batt plugged-in: yellow 1s, green 1s
		Batt unplugged: red 1s, off 1s
HVG	Un-commissioned With network connectivity	Batt plugged-in: yellow 1s, green 1s
		Batt unplugged: red 1s, off 1s
HVG	Un-commissioned Without network connectivity	Batt plugged-in: yellow 250mS, green 250mS, yellow 250mS, green 250mS, green 1s
		Batt unplugged: red 250mS, off 250mS, red 250mS, off 250mS, off 1s
ZW, DATA	Emergency Light Test In Progress	LED flashes at yellow 5s, Off 1s
HVG	Emergency Light Test In Progress	LED flashes at yellow 1s, Off 1s

In the case of the DATA version a 2-way “figure 8” cable and terminal block facilitates the connection to the DATA network via a multi-drop bus (daisy chain connection). For further information of installation of a Zoneworks system, please refer to the Zoneworks Users Guide and Commissioning Guide (incl. DATA version)

DALI 2 EM Option

Luminaires with part numbers having -D2 are fitted with DALI 2 certified modules (nodes) that facilitate connection and integration to 3rd Party Lighting Control Systems. Before installing the fitting, please confirm that the Lighting Control System has the capability to monitor DALI Emergency Luminaires. The fitting will be addressed and configured into the control system by the Lighting Control System Commissioning Technicians and not Clevertronics.

State	LED Operation
Commissioned/ Un-commissioned	LED on Solid (Green)
Emergency Light Test in progress	LED flashes at 1s On (Yellow) & 1s Off
“IDENTIFY COMMAND”	Lamp and Status LED Flash for 30 seconds

A 2-way “figure 8” cable and terminal block facilitates the connection to the DALI network OR a 5/6way “structured wiring system” lead and plug facilitating the power and DALI connection. DALI connections are marked as Da Da.

Microwave Sensor Option

Refer to the supplementary operation guide supplied with the Product.
– [Clevertronics Stallion Driver, Sensor Adjust](#).

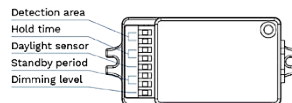

IP20 CIRCULAR LED Luminaire Installation & Maintenance Instruction Leaflet



NOTE: Standard product codes with this symbol are enabled with Clevertest Plus capability. Please refer to the operation guide supplied with the product for details.



Australia (Head Office)
Website: www.clevertronics.com.au
Email: info@clevertronics.com.au
Phone: +61 3 9559 2700

UK OFFICE
Website: www.clevertronics.co.uk
Email: sales@clevertronics.co.uk
Phone: 01895 430 255

Models:

CIRC-xx-LP-yy-uu

Testing:

Manual Test yy = Blank
Zoneworks HIVE yy = HVG
DALI-2 yy = D2

Options:

Microwave Sensor **xx** = SEN
Dali Driver **xx** = DD
Custom Colour **uu** = Colour

Spare Parts:

1553231	Replacement Battery
8051420	Replacement Emergency LED Board
UKM02370320002	Replacement Emergency Driver
1330102	Replacement 240V Driver
1330067	Replacement 240V Driver (-DD)
1330103	Replacement Microwave Sensor (-SEN)

Important:

It is illegal for anyone, except for a licensed electrician to install or maintain this product. Before installation, ensure that the electricity supply has been switched off and isolated. Installation must be carried out in accordance with the relevant British Standards.

Installation:

This product is a surface ceiling or wall mount fitting. Please follow below image and steps to install :

- Anti-clockwise rotate the diffuser (facing towards the diffuser) then lift it from the base to remove it.
- Loosen the x4 LED board screws and rotate the board to clear the screw heads from their securing keyhole.
- Drill cable entry hole and mounting holes in the base.
- Position the circular light to desired location and mark out the fixing points on the mounting surface.
- Install appropriate fixing hardware .
- Route power supply cables through entry hole and fasten the circular light to the surface.
- terminate the supply cable to the terminal block according to the marked designation (L_{EM}, N, L_{SW}, \oplus , DA, DA)
- Make sure battery is connected to the emergency driver. (For Non-Sensor version) Select Hi / Lo light level output.
- Reinstall the LED board by slotting the keyholes back to the x4 secure screws and tighten them.
- Set the LED CCT switch to desired colour (3000K / 4000K / 5700K) and reinstall the diffuser.

If the CTP capabilities are activated, please affix the CTP status label to a visible surface and Four Segment Marking on the product will include an "F" in third segment block.

Dimensions:

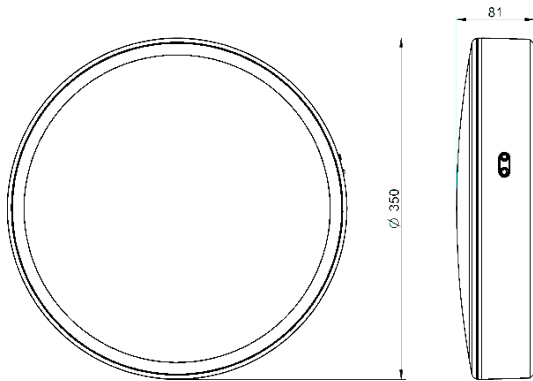

Note:

This luminaire (with reinforced insulation between control/LED terminal and AC supply) contains non-user replaceable light source and battery - to be replaced (if required, refer installation instructions for battery replacement) by Clevertronics service personnel/agents or a registered electrician.

If flexible wiring is connected to this luminaire and is within arms reach, the wiring shall be effectively fixed to the wall to reduce the risk of strangulation.

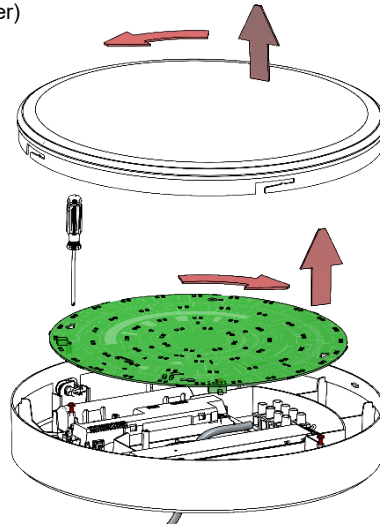

Driver Setting:

(Non-Sensor Version Only)

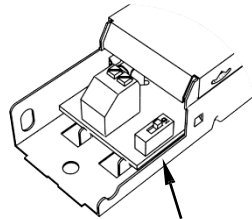

ON – High Lumen Output
OFF – Low Lumen Output

Battery Replacement:

1. Prior to any work, isolate the power to the luminaire that requires battery replacement.
2. Remove diffuser and LED board as per installation section.
3. Disconnect the battery connector, remove battery from the holder.
4. Replace with new battery and reconnect to Emergency Driver.
5. Reinstall the LED board and diffuser as per installation section.

Testing Procedure:

When the unit is connected to the un-switched active, it must be allowed to charge the battery for at least 24 hours. The emergency lamp only illuminates during a power fail. Conduct the following tests:

- The emergency lamp must illuminate for at least 180 min after disconnection from the mains. If the unit fails to illuminate for the requisite time, remedial action must be taken to repair the situation and once completed, the unit must pass a subsequent test.
- Press and hold Test Button or switch Off Mains Supply, check that the emergency lamp is On.
- Release the Test Button or Switch On Mains Supply, check that the emergency lamp is Off (Non-maintained operation).

Trouble Shooting:

Below are a list of common problems and their possible causes.

Fault: The Green LED indicator is not illuminated.

Check: A.C. is connected and is turned on.
Battery is connected.

Fault: Lamp does not illuminate in emergency mode.

Check: A.C. is connected.
Lamp is correctly inserted.
Battery is connected.

Fault: Lamp illuminates in emergency mode, but only stays on for a short period.

Check: Battery has been allowed to charge for at least 24 hours.
Battery for damage.

Caution:

On many building sites, power circuits may be cut off in an uncontrolled and repetitive basis during construction. As a result, any Exit & Emergency Units, on these circuits, will have their batteries discharged or "cycled". The Li-ion battery in the Exit & Emergency Unit has been selected to give excellent long life performance in a controlled IEC 60598-2-22 testing environment. Excessive battery cycling will reduce through-life performance and may lead to premature battery failure. Battery warranty claims, as a result of such abuse, are specifically EXCLUDED from Clevertronics warranty terms.

Warranty:

For Product Warranty information and Terms and Conditions of Sales please refer to our website <https://clevertronics.co.uk/product-warranty-statement/>